



## METAL SEPARATOR FOR THE PROTECTION OF INJECTION MOULDING MACHINES AND EXTRUDERS

### TECHNICAL DATA SHEET

Version 10/18

---

Find more references and technical data  
on our online catalogue :  
[www.bmsfrance.eu](http://www.bmsfrance.eu)

 Find illustrative videos  
on our Youtube channel

---

 53, route des Contamines  
74370 Argonay - France

---

 Tél. : +33 (0)4 50 27 29 00 - Fax. : +33 (0)4 50 27 38 22

---

 [info@bmsfrance.eu](mailto:info@bmsfrance.eu)

---

 [www.bmsfrance.eu](http://www.bmsfrance.eu)

**DIMENSIONS – NOMINAL WIDTH 30 - 40**

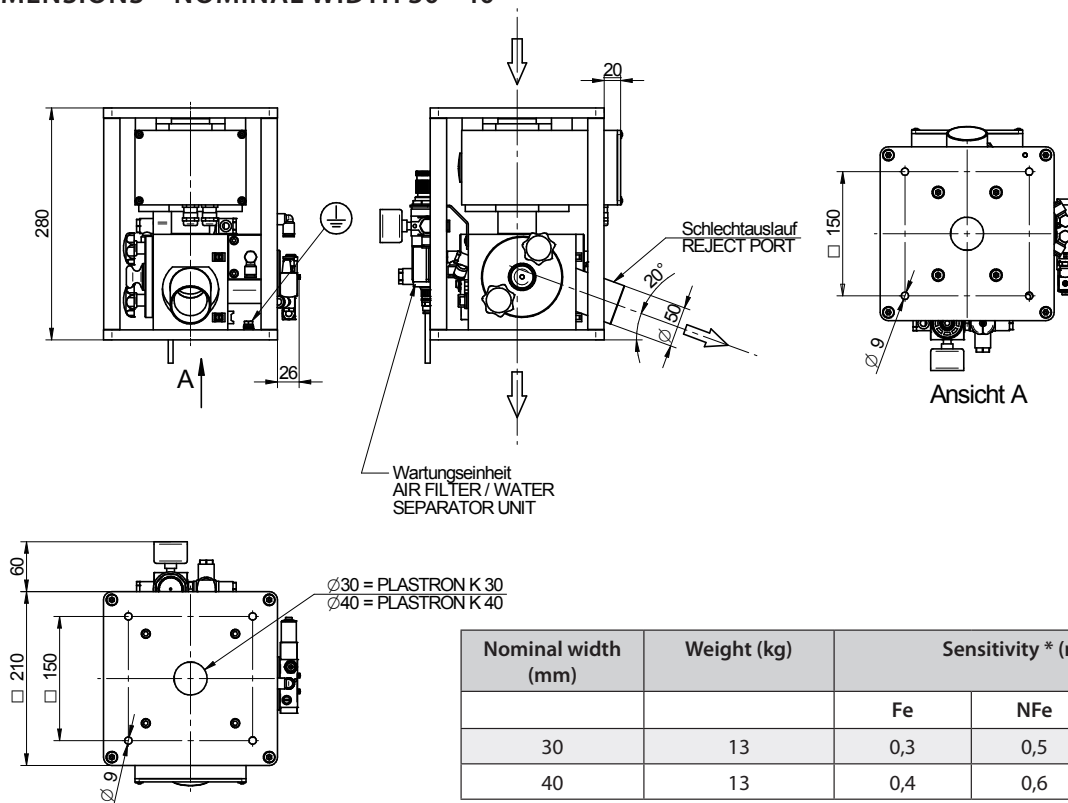

**DIMENSIONS – NOMINAL WIDTH 50 - 70**

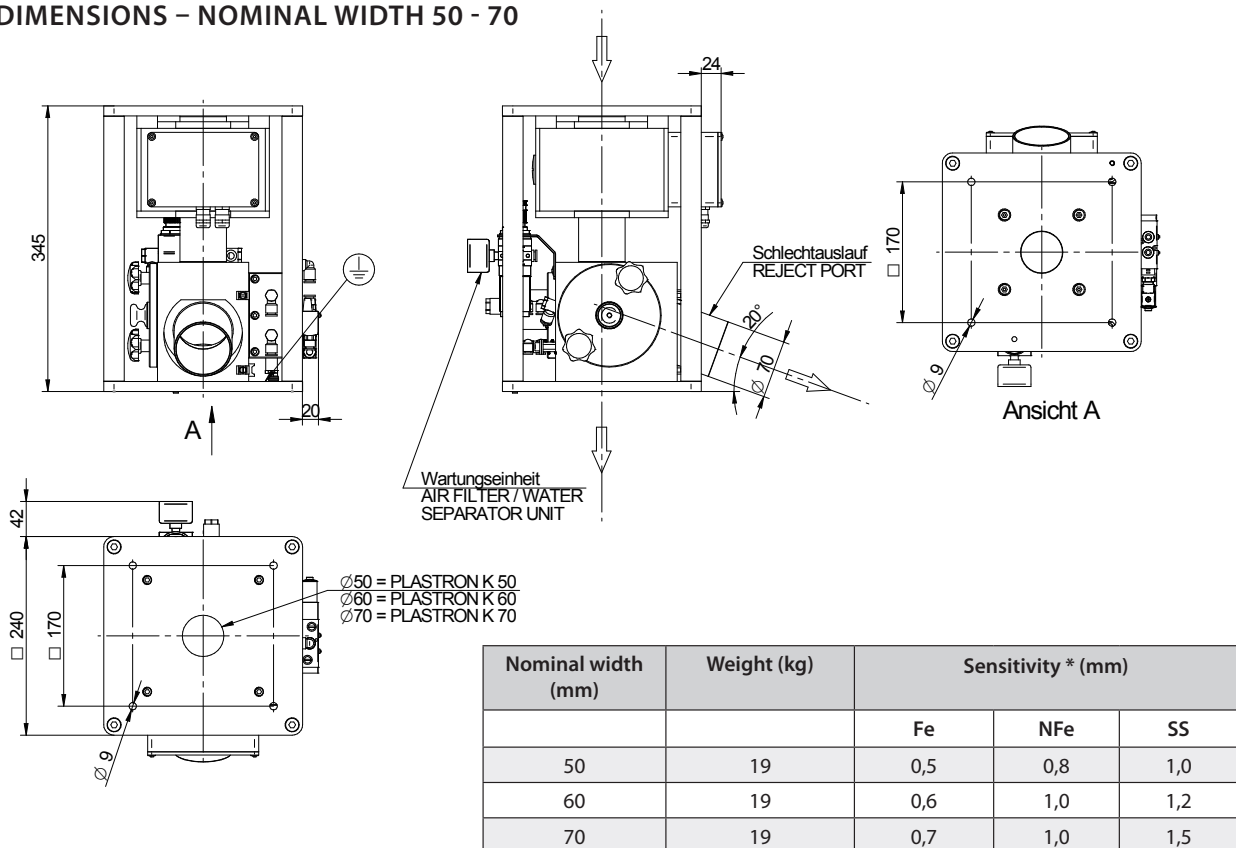

Find more references and technical data on our online catalogue : [www.bmsfrance.eu](http://www.bmsfrance.eu)

53, route des Contamines  
74370 Argonay - France

Tél. : +33 (0)4 50 27 29 00 - Fax. : +33 (0)4 50 27 38 22

info@bmsfrance.eu

@ www.bmsfrance.eu

Find illustrative videos on our Youtube channel

## DIMENSIONS – NOMINAL WIDTH 100 - 120

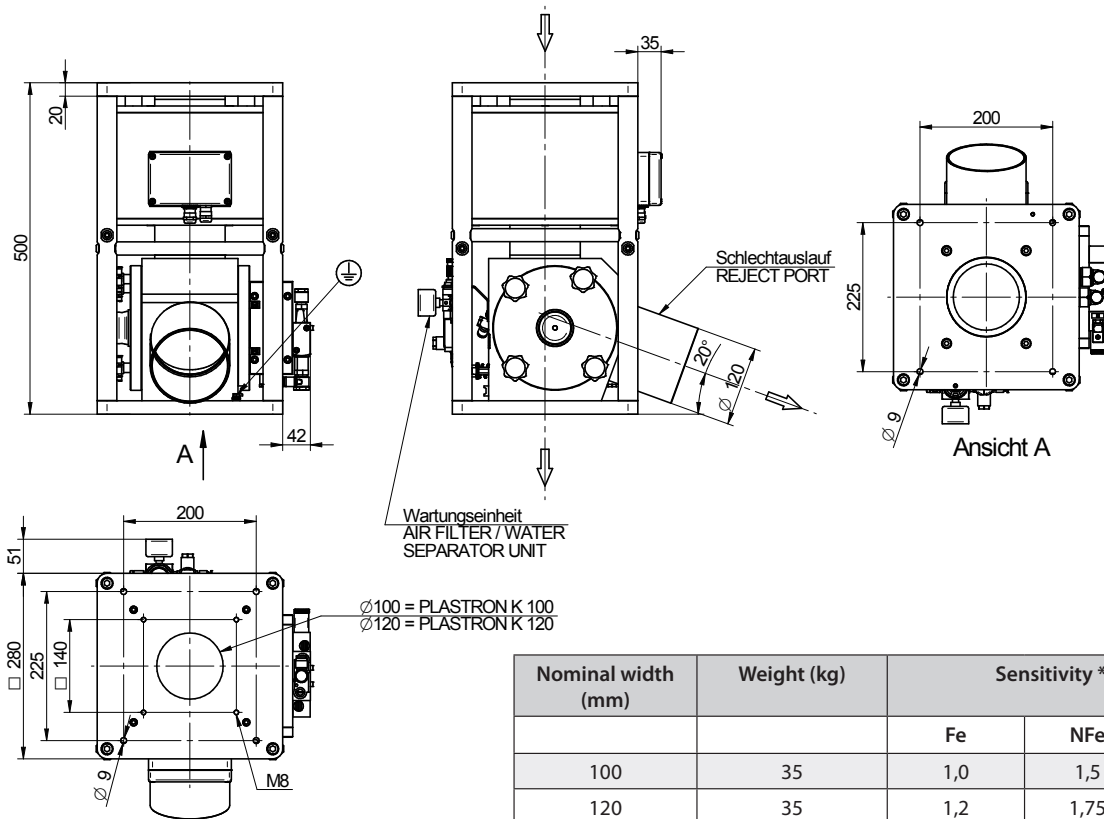

\*The sensitivity depends on the nominal passage width of the metal separator. The smaller the nominal width, the higher the sensitivity. The values given in the table were measured in the centre of the passage opening under simulated production conditions and are valid for most dry powders and granulates. If you can provide our Application department with suitable product samples, we will be glad to inform you of the maximum possible sensitivity values for the product in the specific project.

Find more references and technical data on our online catalogue : [www.bmsfrance.eu](http://www.bmsfrance.eu)

53, route des Contamines  
74370 Argonay - France

Tél. : +33 (0)4 50 27 29 00 - Fax. : +33 (0)4 50 27 38 22

[info@bmsfrance.eu](mailto:info@bmsfrance.eu)

[www.bmsfrance.eu](http://www.bmsfrance.eu)

Find illustrative videos on our Youtube channel

## TECHNICAL DATA

- Protection class: IP 65
- Operating voltage: 100 to 240 V AC / 50 / 60 Hz
- Appliance fuse: 1,25 A time-lag, 5x20 mm according to DIN
- Power consumption: max. 50 W
- Compressed air connection: 6–10 bar (up to 40 °C)
- Compressed air consumption: PLASTRON K 30–70 = 6 l per separation  
PLASTRON K 100/120 = 9 l per separation
- Operating pressure: 6 bar
- Maximum permissible load (vertical): 500 kg

## AREA OF USE

The area of use of the machine is the feeding of injection moulding machines and extruders with slow-flowing material in plastics processing. It protects the processing machine against damage caused by metal parts and guarantees an optimum production process for your area. The PLASTRON 05 K is installed directly at the machine intake between the inlet of the plasticiser unit and the upstream peripheral devices.

- Ambient temperature: +5 °C to +50 °C
- Storage temperature: -10 °C to +60 °C
- Relative humidity: 0 to 100 % (without condensed water)
- Conveying method: Slow-moving material column or short free fall
- Conveying speed: 0,005–2,0 m/s
- Fall height: 150 mm above the top edge of the appliance
- Material to be examined: Thermoplastics, thermoplastic elastomers and common additives
- Granulation: 0–6 mm (granulate/powder) 1–10 mm (flakes)
- Material temperature: max. 120 °C

## STANDARD SCOPE OF DELIVERY

- Operating manual
- EU Declaration of conformity
- 1.8 m mains power cable
- Mounting frame
- Detection coil
- Separation mechanism
- Compressed air maintenance unit
- 2.5 m compressed air connection
- AMD 05 evaluation electronics
- 2 m connecting cable between electronics casing and appliance

## AVAILABLE ACCESSORIES / OPTIONS

- Appliance version for abrasive granulates
- Visual and acoustic signalling devices
- Special lengths of connecting cables between appliance and electronics casing of up to 50 m
- Mains power cable with other standard plugs
- Automatic monitoring of the compressed air and separation mechanism
- Adaptor plates for mounting
- Product emptying at the push of a button

Find more references and technical data  
on our online catalogue :  
[www.bmsfrance.eu](http://www.bmsfrance.eu)

🏠 53, route des Contamines  
74370 Argonay - France

☎ Tél. : +33 (0)4 50 27 29 00 - Fax. : +33 (0)4 50 27 38 22

✉ [info@bmsfrance.eu](mailto:info@bmsfrance.eu)

@ [www.bmsfrance.eu](http://www.bmsfrance.eu)

▶ Find illustrative videos  
on our Youtube channel